

LCJ-10T-3 Grain Blending Machine

◆ Application

Grain processing, chemical, port and other industries that require continuous operation and automatic control of material flow rate.

◆ Main configuration

No.	Name	Brand
1	Weighing Controller	Canada/Gerenral Measure
2	Power Switch	Taiwan/Mingwei
3	Button /Knob	French/Schneider
4	Load Cell	ZEMIC
5	Contactora	French/Schneider
6	French/Schneider	French/Schneider
7	Gear Reducer	Zhejiang/JIAXUE
8	Pneumatic Element	Taiwan/Airtac

◆ Technical parameters

Model	LCJ-10T-3
Capacity (t/h)	10
Accuracy	≤0.5%
Power (KW)	0.3
Installation Height (mm)	1080

◆ Features

- ▲ Gravity method for flow control, users only need to set the flow value and adjustment gate on weighing controller. Easy to check the real-time current weight, current flow value, cumulative value and target value on the meter;
- ▲ The entire production process of the product is continuous;
- ▲ Operating parameters and control parameters will be reserved after power off;
- ▲ Settable amount can be set: when the cumulative amount reaches the target value, the meter will stop working automatically.

◆ Photo



佳龙
JIALONG

LCJ-10T-3

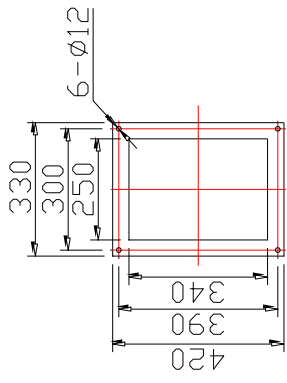
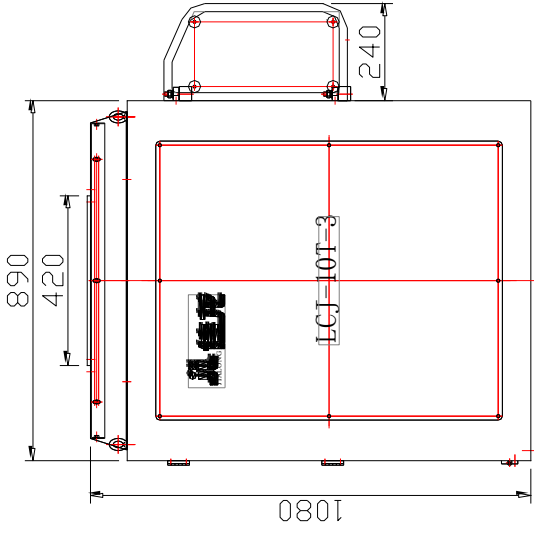
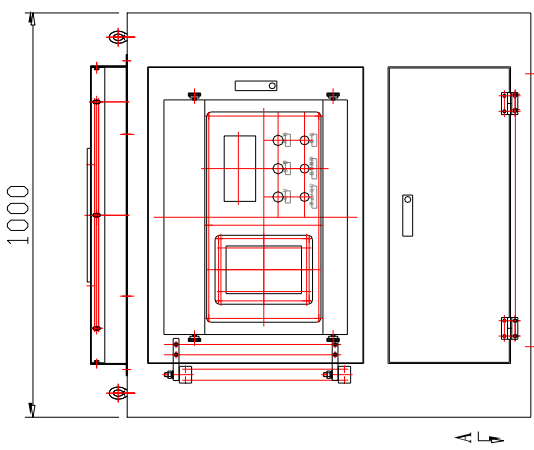

料仓法兰安装尺寸

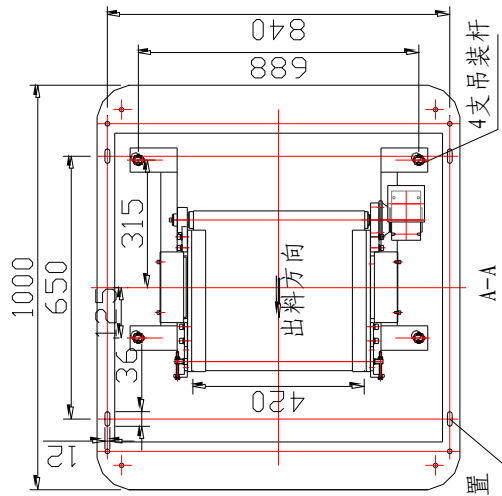

安装位置

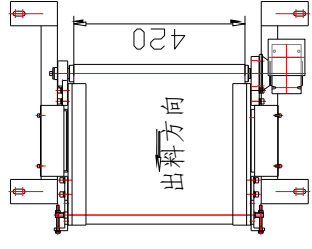

配料输送装置

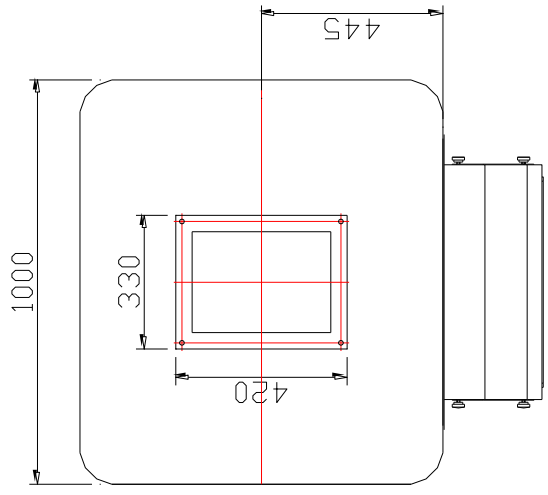

漳州佳龙 科技股份有限公司		安装尺寸图 (无支架)		LCJ-10T-3	
标记	数量	分区	更改文件号	签名	年、月、日
设计			标准化		
绘图					
审核					
工艺					
阶段标记			数量	比例	
B			1	1:10	
共 1 张 第 1 张					